

D300B-T2V Dry Rotary Vane Vacuum System

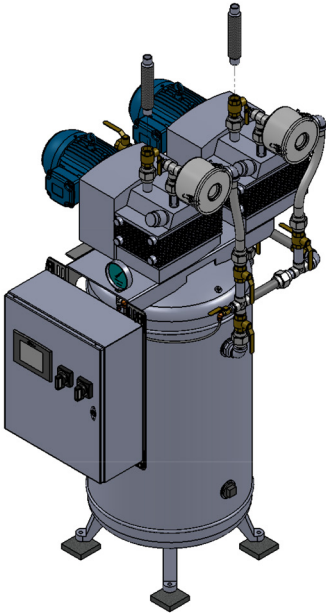

Configuration	Duplex Vertical Tank Mount
System Capacity	11.7 SCFM @ 19" Hg
Motor Horsepower (HP)	3 HP
Total System Horsepower	6 HP
Receiver Size	80 Gallons
Available Voltage	230/460 3 Phase contact factory for other voltages
Note: System capacity is stated with one pump in reserve.	

VACUUM PUMP MODULE

- Oil-Less, Air Cooled Rotary Vane Vacuum Pumps
- Each Pump Contains: Vacuum Filter & Inlet Check Valve
- Pump Isolation Valves for Ease of Service

AIR RECEIVER

- Constructed to ASME Standards
- Rated for Full Vacuum
- Equipped with 3 Valve Bypass
- Highly Visibility Vacuum Gauge
- Source Isolation Valve Included
- Includes: Mounting Pads & Flex Connectors

SYSTEM CONTROLS

- Underwriters Laboratories Listed
- Nema 12 Enclosure
- Safety Disconnect Handles
- Fuseless Design
- HMI (Human Machine Interface) System
- NFPA Required Local Alarms

OPTIONS

- Inlet Liquid Separators